

Code number	M900-01
Groove density	900grooves/mm
Wavelength range	200-1000nm
Dimensions	20x20mm
Central thickness	5mm

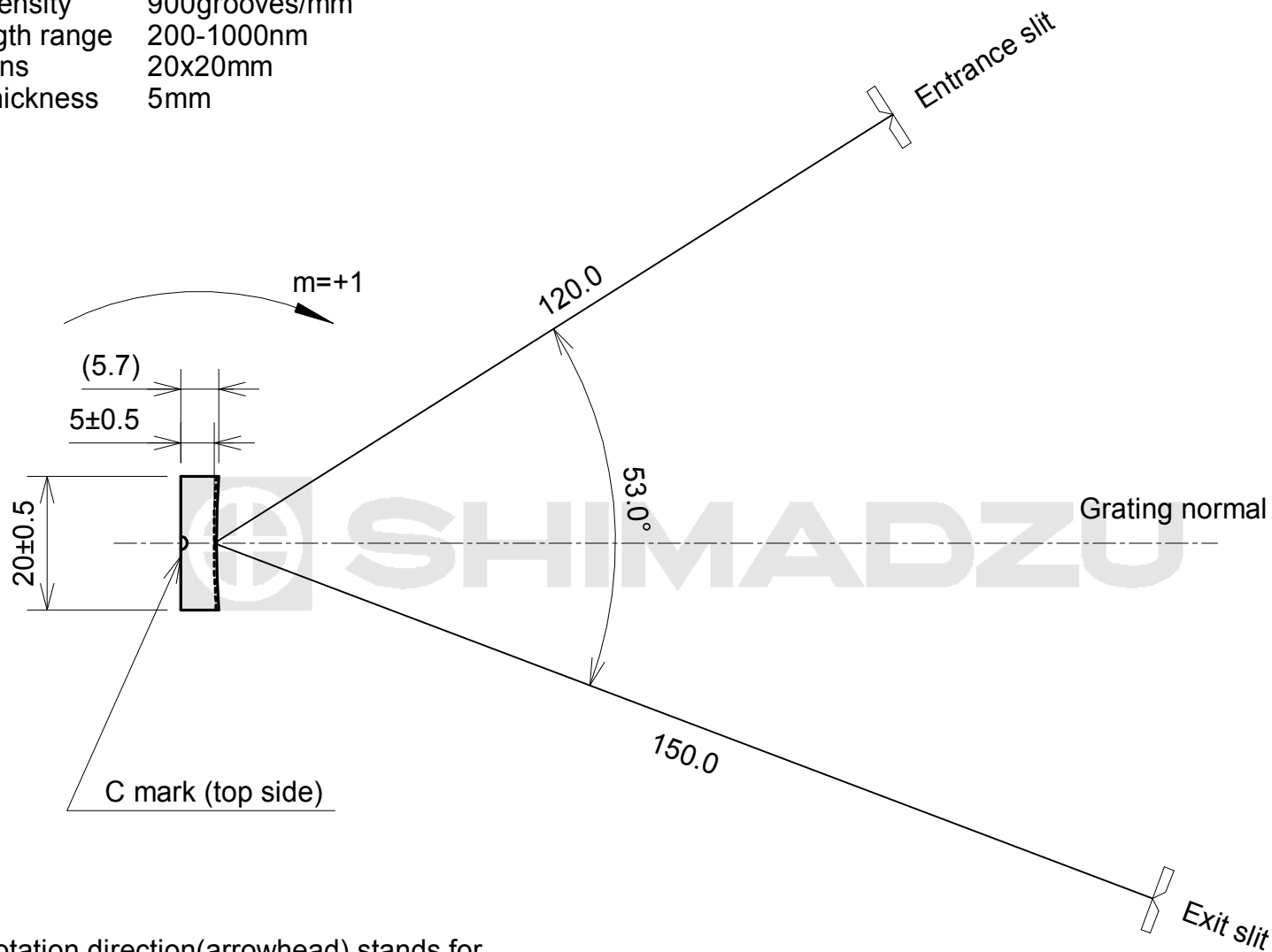

The rotation direction (arrowhead) stands for scanning direction from short to long wavelengths.

C mark : Indentation on rear side to indicate mounting direction