

| | |
|-------------------|---------------|
| Code number | M0900-04 |
| Groove density | 900grooves/mm |
| Wavelength range | 200-1000nm |
| Dimensions | 54x54mm |
| Central thickness | 8.9mm |

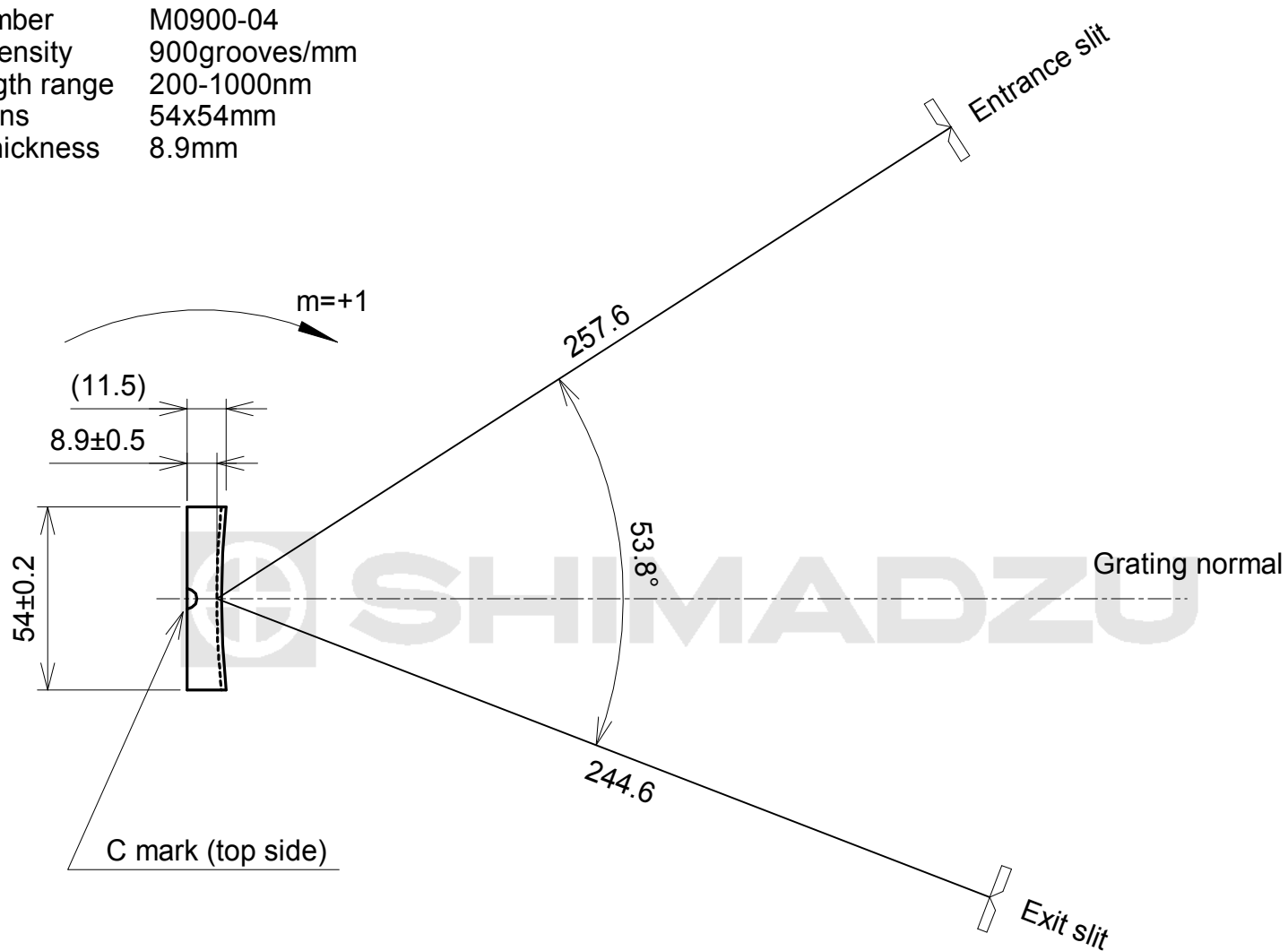

The rotation direction(arrowhead) stands for scanning direction from short to long wavelengths.

C mark : Indentation on rear side to indicate mounting direction