

Code number	M1198-01,-02,-03
Groove density	1198grooves/mm
Wavelength range	200-800nm(M1198-01) 350-850nm(M1198-02) 190-800nm(M1198-03)
Dimensions	42.4(W)x42.4(H)mm
Central thickness	7.7mm

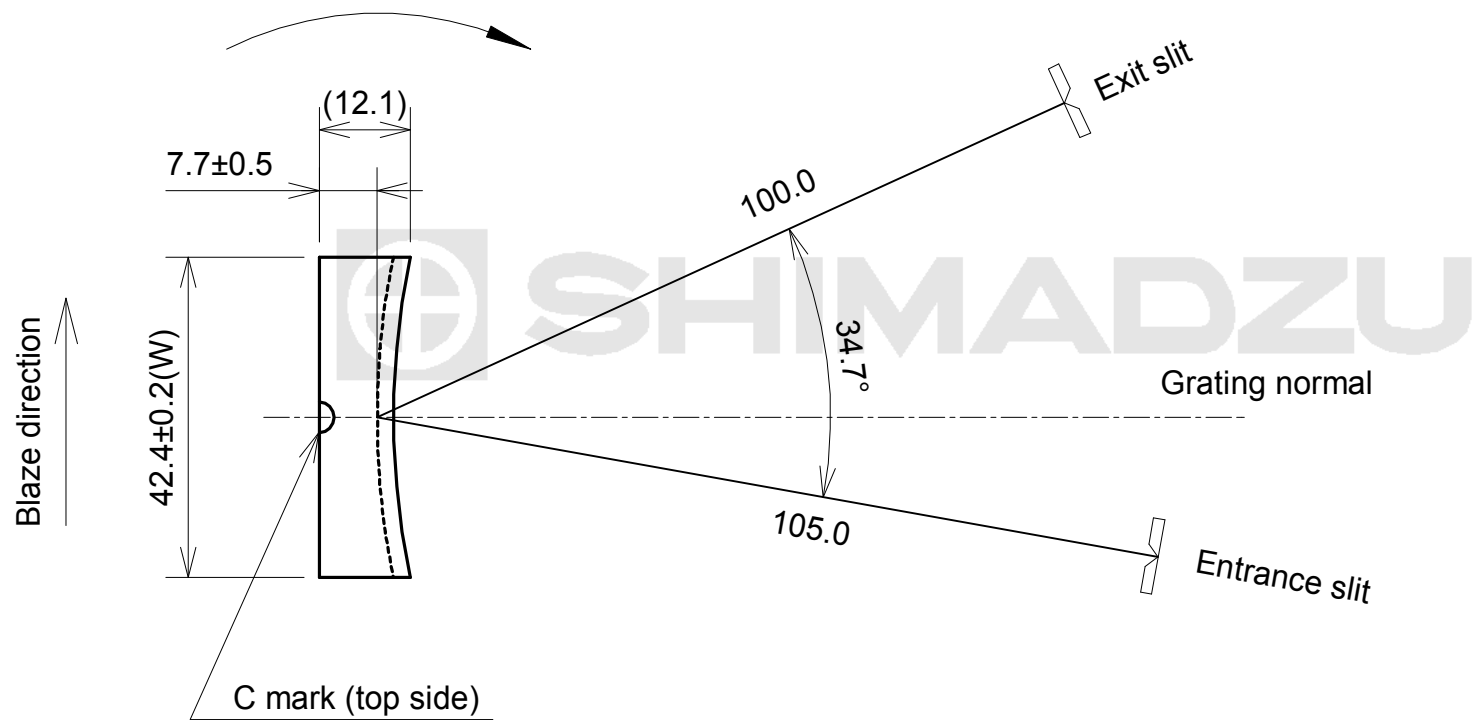

The rotation direction (arrowhead) stands for scanning direction from short to long wavelengths.